

THIS DRAWING IS UNPUBLISHED. RELEASED FOR PUBLICATION ,19 .
 © COPYRIGHT 19 BY AMP INCORPORATED. ALL RIGHTS RESERVED.

LOC		DIST		REVISIONS			
P	LTR	DESCRIPTION	DATE	DWN	APVD		
G	14	G	REDRAWN PER 0720-0377-94	100CT94	LO	ME	

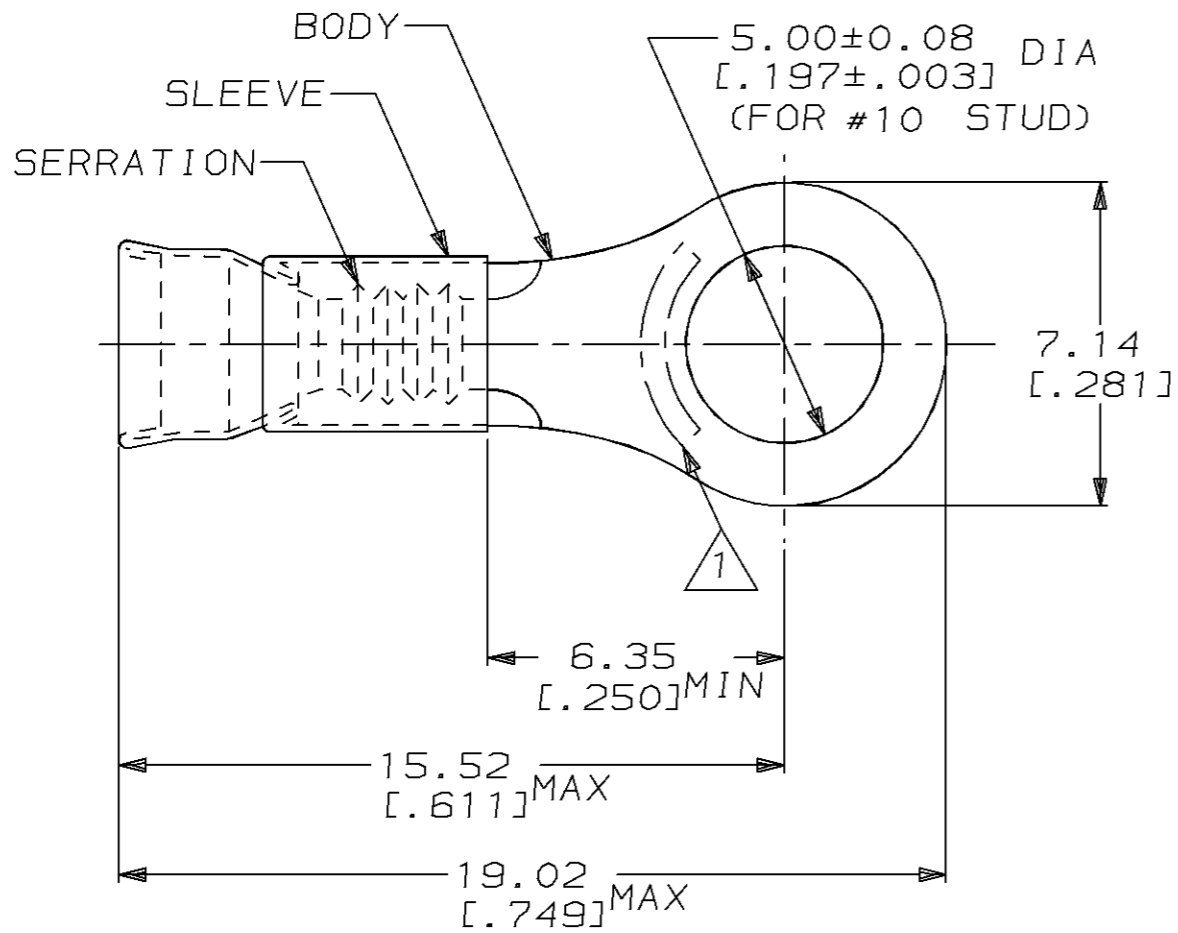

- 1. STAMP AMP 22-18*APPROX AS SHOWN
 22-16 TERMINALS ARE STAMPED 22-18 IN
 ACCORDANCE WITH MILITARY SPEC MIL-T-7928
 COMMERCIAL WIRE RANGE IS 22-16
- 2. WIRE INSUL DIA, 2.67-3.56 [.105-.140]
- 3. TONGUE MATL THK, 0.79±0.05 [.031±.002]

1000	LOOSE PIECE	322366
QTY	PACKAGE TYPE	PART NO

AMP INCORPORATED CUSTOMER SERVICE SYSTEM		MAX RECOMMENDED OPERATING TEMPERATURE: 343°C [650°F]	THIS DRAWING IS A CONTROLLED DOCUMENT FOR AMP INCORPORATED. IT IS SUBJECT TO CHANGE AND THE CONTROLLING ENGINEERING ORGANIZATION SHOULD BE CONTACTED FOR THE LATEST REVISION.		DWN L OLMEDA 100CT94	AMP Incorporated Harrisburg, PA 17105-3608
FOR ADDITIONAL PRODUCT INFORMATION OR COPIES OF DRAWINGS AND TECHNICAL DOCUMENTS	PRODUCT INFORMATION CENTER 1-800-522-6752		DIMENSIONS: mm [in]	TOLERANCES UNLESS OTHERWISE SPECIFIED:	CHK M ELLIS 100CT94	
FOR APPLICATION TOOLING INFORMATION	TOOLING ASSISTANCE CENTER 1-800-722-1111	VOLTAGE RATING: -		0 PLC ±-	1 PLC ±-	PRODUCT SPEC
FOR ORDER ENTRY	1-800-526-5142	CIRCULAR MIL AREA: 0.26mm ² -1.65mm ² [509-3260]		2 PLC ±0.20 [.008]	3 PLC ±-	4 PLC ±-
		STRANDED WIRE	MATERIAL BODY, CU PER ASTM B152 SLEEVE, NI SIL PER ASTM B122	FINISH BODY, NP, QQ-N-290	WEIGHT -	SIZE A3
					CUSTOMER DRAWING	CAGE CODE 00779
						DRAWING NO G-322366
						SCALE 6:1
						SHEET 1 OF 1
						REV G